

SMD QUARTZ CRYSTAL RESONATOR

2 Pad Version 3.2×1.5 mm

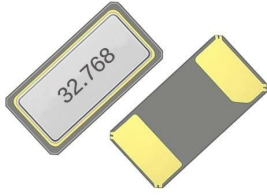

- Tuning fork crystal in standard package
- 32.768 KHz standard
- ±20 ppm Standard
- Excellent Reliability Performance
- Reflow soldering temperature: 260°C max



RoHS compliant

★ PARAMETERS

PARAMETERS	SPECIFICATION
Frequency Range	32.768KHz
Loading Capacitance	12.5pF Std. 6pF、7pF、9pF available
Drive Level	1.0 μ W Max
Frequency Tolerance	±10ppm / ±20ppm (at 25℃)
Equivalent Resistance	70KΩ Max (50KΩ available)
Temperature coefficient	-0.04×10 ⁻⁶ /°C ² Max
Operating Temp. Range:	-40~+85℃ (-40~+125℃ available)
Storage Temp. Range:	-40~+85℃
Aging (25℃, First Year)	±3ppm Max

○ All specification subject change without notice.

★ DIMENSIONS& LAND PATTERN LAYOUT (Unit: mm)

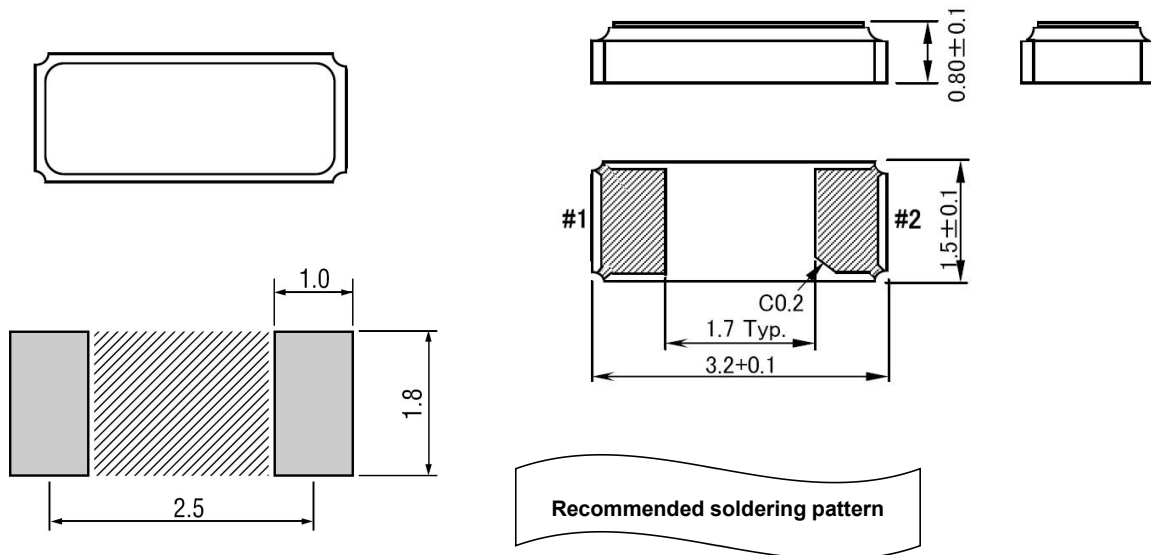

★ PART NUMBER GUIDE e.g. FTX32.768K12.5SM3-20D (*SM3=3.2×1.5 SMD)

	Quartz Crystal Resonator	Frequency Hz	Load Capacitance pF	Package	Frequency Tolerance ppm	Operating Temp. Range
FT	X	32.768KHz	12.5	SM3	20	D

Definition	Description	
Operating Temperature Range	A: -10~+60°C	B: -20~+70°C
	C: -30~+80°C	D: -40~+85°C
	E: -30~+105°C	F: -40~+105°C
	G: -40~+125°C	S: Customer specified

★ TAPING SPECIFICATION (Unit: mm)

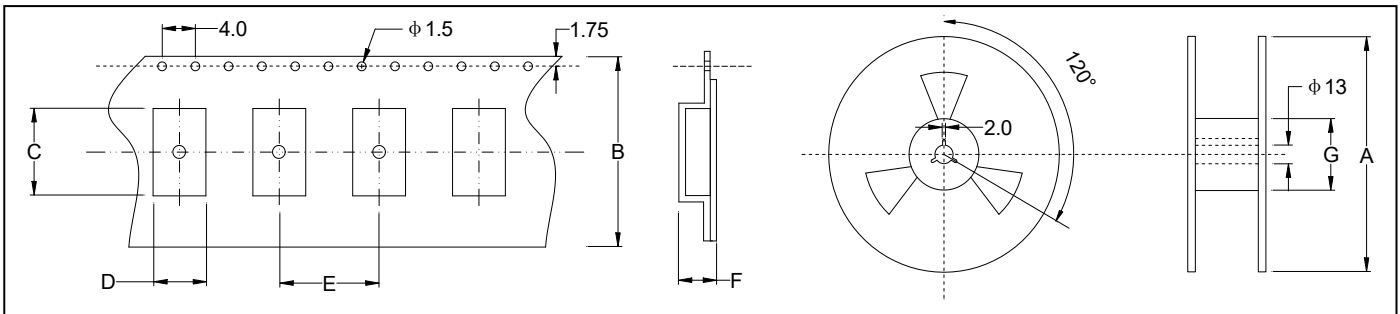

	A	B	C	D	E	F	G
SMD3.2×1.5	180	12	3.45	1.75	4.0	1.0	60
3000 pcs per reel							

★ REFLOW SOLDERING PROFILE

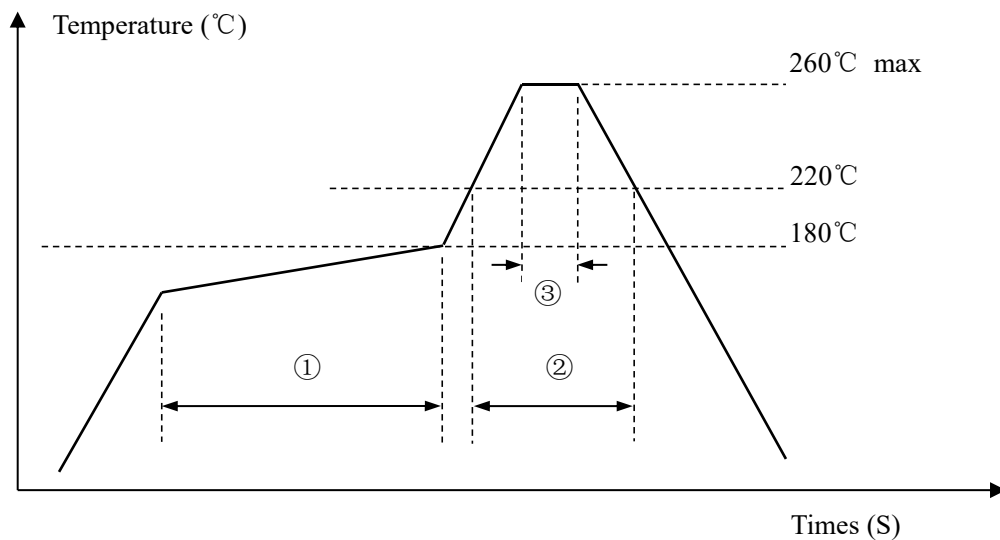

Pb free reflow A	①	Preheat	160~180°C	100sec. max
	②	Primary heat	220°C	35sec. max
	③	Peak	260°C	10sec. max