

SMD QUARTZ CRYSTAL RESONATOR



SMD Tuning Fork Crystal 2.0×6.0 mm

- Tuning fork crystal in standard package
- 32.768 KHz standard
- ±10 ppm available
- Excellent Reliability Performance
- Reflow soldering temperature: 260°C max



RoHS compliant

★ PARAMETERS

PARAMETERS	SPECIFICATION
Frequency Range	32.768KHz standard, 20.000~160.000KHz
Loading Capacitance	12.5pF Std. 6 to 20pF Series available
Drive Level	1.0 μ W Max
Frequency Tolerance	±10ppm~±30ppm (at 25°C)
Equivalent Resistance	50KΩ Max
Temperature coefficient	-0.04×10 ⁻⁶ /°C ² Max
Operating Temp. Range:	-20~+70°C / -40~+85°C
Storage Temp. Range:	-55~+125°C
Aging (25°C, First Year)	±3ppm Max

○ All specification subject change without notice.

★ FREQUENCY STABILITY VS. TEMPERATUR

Operation Temperature Range	Frequency Stability	
	-80ppm	-160ppm
-20°C~+70°C	●	
-40°C~+85°C		●

● standard ○ available

★ ESR (SERIES RESISTANCE RS)

Frequency	20-30KHz	30-40KHz	40-70KHz	70-160KH z
ESR	50KΩ Max	45KΩ Max	20KΩ Max	12KΩ Max

★ DIMENSIONS& LAND PATTERN LAYOUT (Unit: mm)

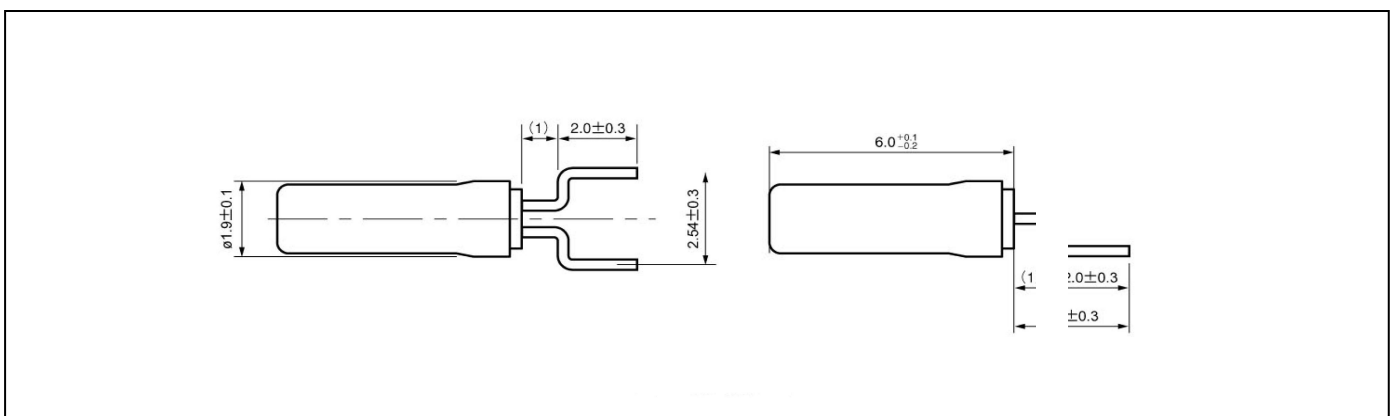

★ PART NUMBER GUIDE e.g. FTX32.768K12.5FM206-20 (*FM206=2.0×6.0mm SMD)

	Quartz Crystal Resonator	Frequency	Load Capacitance pF	Package	Frequency Tolerance ppm	Operating Temp. Range
FT	X	32.768KHz	12.5	FM206	20	D

Definition	Description	
Operating Temperature Range	A: -10~+60°C	B: -20~+70°C
	C: -30~+80°C	D: -40~+85°C
	S: Customer specified	

★ TAPING SPECIFICATION (Unit: mm)

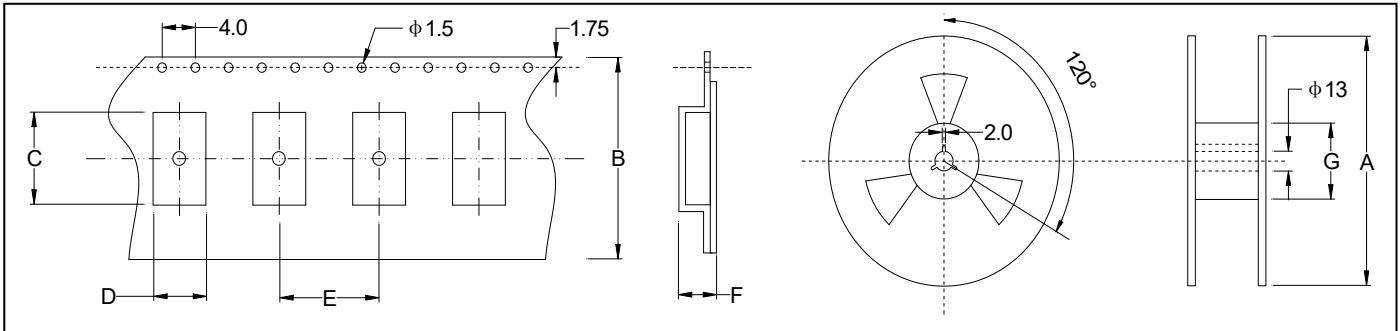

	A	B	C	D	E	F	G
FM206	178±2.0	16.0±0.3	8.4±0.1	4.0±0.1	8.0±0.1	2.8±0.1	60.5±1.0
1000 pcs per reel							

★ REFLOW SOLDERING PROFILE

